

PRO-PLUS[®]

Trench Drain System

Quality Engineered SMC/GRP Trench Drains



Josam.com

JOSAM[®]

A **WATTS** Brand

PRO-PLUS® TRENCH DRAIN SYSTEM

Josam has revolutionized the drainage industry with the PRO-PLUS® Trench Drain System. The PRO-PLUS® trench drain is available in two widths and depths and offer a wide range of grates that provide the solutions you need to meet your application requirements.

With the PRO-PLUS® trench drain system a free-of-charge technical design service is offered providing hydraulic calculations, CAD drawings, quantity schedules, and product specifications. Below is a sample.

Make sure to visit us online at www.josam.com to find more information such as:

- Library of technical drawings
- Locate a local representative
- Get a quote
- Request a brochure
- Compare products
- View additional product lines
- List Price Items
- Product Listings
- Layout Drawings

SAMPLE INSTALLATION DRAWING AS PROVIDED BY JOSAM

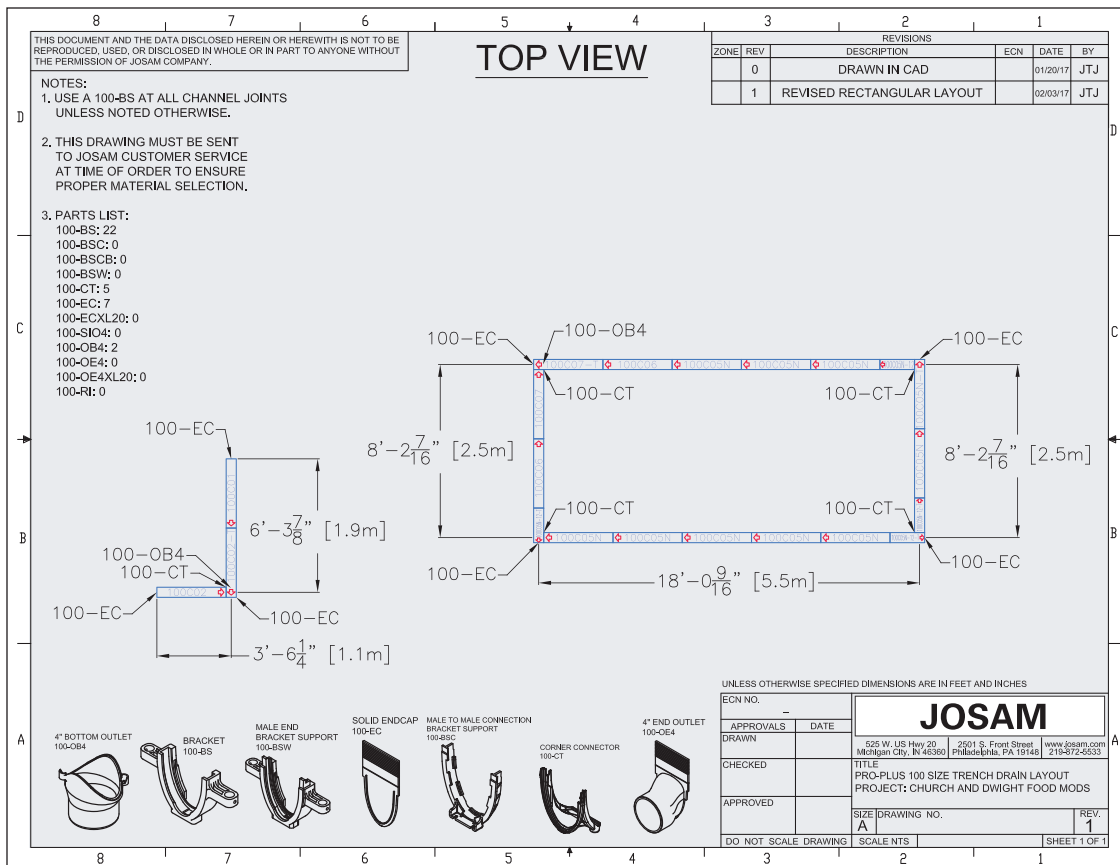



PRO-PLUS[®]

Trench Drain System

SMC/GRP PRO-PLUS [®] material	4
PRO-PLUS [®] Proven Results.....	5
PRO-PLUS [®] Chemical Resistance	6
PRO-PLUS [®] Benefits and Accessories	7-9
PRO-PLUS [®] Channels and Options	10
PRO-SNAP [®] Securing System	11
Grate Options	12
PRO-SNAP [®] Grates.....	13
PRO-PLUS [®] 100 Series Grates	14
PRO-PLUS [®] 100 and 200 Series Grates	15

Refer to the Josam PRO-PLUS[®] Price Sheet or www.Josam.com for Terms and Conditions.



A **WATTS** Brand

PRO-PLUS® is manufactured using glass-fiber reinforced polyester (GRP) pressed from sheet molding compound (SMC), which is a composite of polyester resin, mineral fillers and glass-fiber mats.

Key advantages of Josam's innovative SMC/GRP material

- ✓ Shatterproof and extremely resistant to abrasion
- ✓ Frost, heat and rust-resistant
- ✓ Lightweight
- ✓ When using high-temp accessories, it can withstand fluid temperatures of 212°F continuous and 394°F intermittent
- ✓ Non-porous structure with a smooth surface
- ✓ Resistant to chemicals
- ✓ Resistant to oil, gasoline, hot asphalt and tartaric acid
- ✓ Non-flammable
- ✓ Free of halogens, asbestos and toxic heavy metals
- ✓ Capable of being formed into complex shapes
- ✓ An excellent cost / performance material
- ✓ Recyclable
- ✓ Complies with UL 94 HB Fire Rating



Josam's SMC/GRP channels, accessories, and select grates are proudly made in America.

PRO-PLUS® trench drains are perfect for applications such as sidewalks, swimming pools, shopping areas, parking lots, loading docks, commercial kitchens, breweries, airports, and various building facilities.

SMC is a tried and tested GRP material with extremely high strength and dimensional stability. For example, SMC/GRP is more than 1.5 times stronger than polymer concrete. In addition, SMC/GRP's thermal expansion on average is 40% less than that of polymer concrete. These SMC/GRP material characteristics result in extreme rigidity and only minimal longitudinal expansion, even for wide temperature fluctuations. In contrast to thermoplastic polymers, SMC/GRP cannot be reshaped and remains dimensionally stable once heated compression hardens the material into the final product. Glass-fiber reinforced polyester made from SMC

is used wherever extreme conditions prevail and special degrees of durability and rigidity are called for, precisely as in Josam's PRO-PLUS® drainage solutions.

This product is lighter, stronger and expands and contracts in extreme temperature ranges less than polymer concrete. In addition, SMC/GRP has greater compressive, flexural and tensile strength and less thermal expansion properties than either polypropylene or high density polyethylene. SMC/GRP is an innovative material and is clearly superior to all other trench channel materials.

Josam's PRO-PLUS[®] Trench Drains made of SMC/GRP have been tested with proven results that show the advantages of the material and why the PRO-PLUS[®] Trench Drain is unprecedented and in a class by itself.

When considering the Compressive, Tensile, and Flexural Strength, the PRO-PLUS[®] Trench Drain substantially exceeds materials such as polymer concrete, polypropylene, and HDPE.

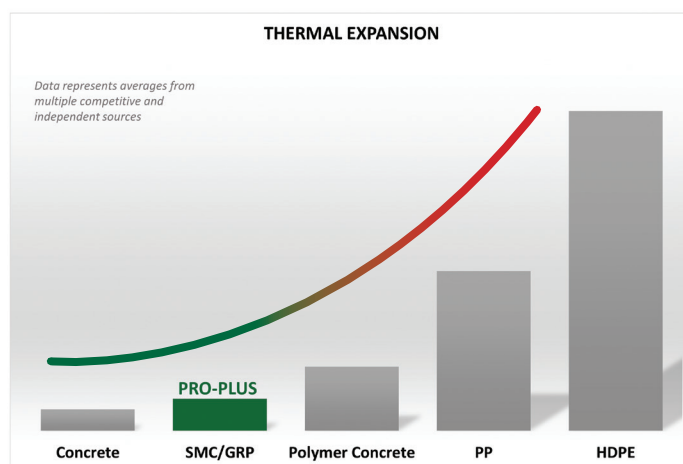
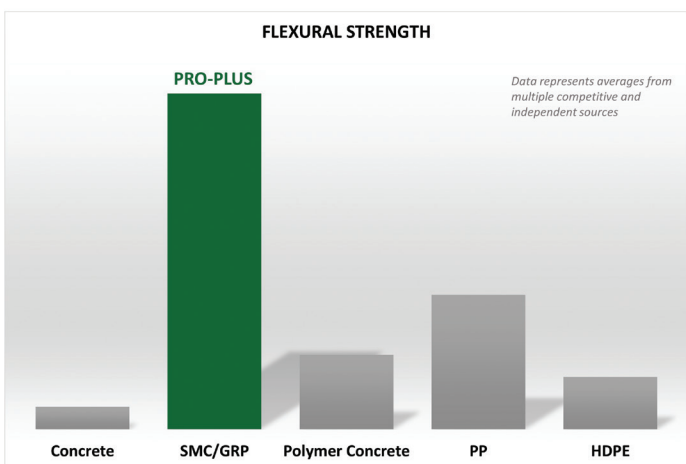
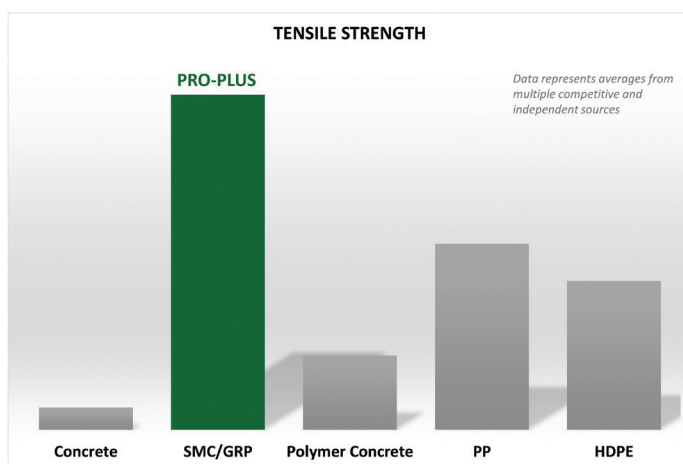
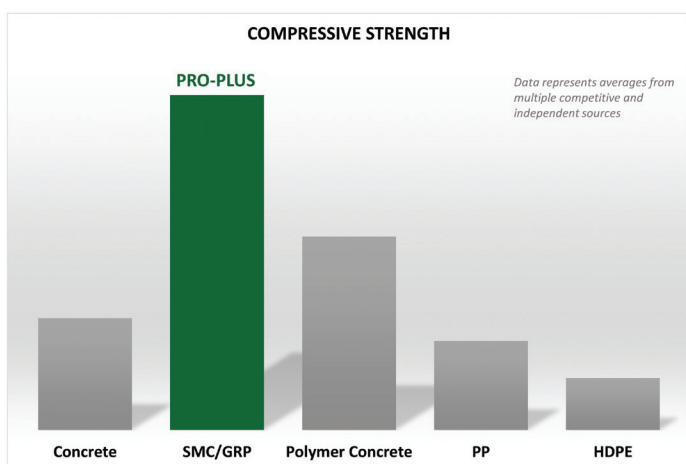

The unique properties of the PRO-PLUS[®] trench drain system allow for considerably less thermal expansion than polymer concrete, polypropylene, and high-density polyethylene.

PRO-PLUS® TRENCH DRAIN CHEMICAL RESISTANCE CHART

	Temperature in F	PRO-PLUS® GRP
Acetic acid 10%	RT	-
	140	-
Acetone	RT	-
Ammonia 25%, aqueous solution	RT	-
Ammonia 5%, aqueous solution	RT	-
Ammonium salts, aqueous solution	RT	+
Apple Juice, aqueous solution	RT	+
Barium salts, aqueous solution	RT	+
Beer	RT	+
Benzene	RT	+
Blood	RT	+
Boric acid	RT	+
Brake fluid	RT	+
Butanol	RT	+
Butyl acetate	104	-
Butyric acid	RT	+
	104	-
Calcium chloride, aqueous solution	RT	-
Calcium hydroxide (lime solution)	RT	-
Calcium salts, aqueous solution	RT	+
Carbon dioxide, aqueous solution	RT	+
Carbon tetrachloride	RT	-
Chlorine water	RT	-
Chlorine, gaseouse, wet	RT	-
Chromic acid 10%	RT	+
Citric acid aqueous solution	RT	+
	140	-
Copper salts, aqueous solution	RT	+
Crude oil	RT	+
Crude petroleum	RT	+
Cyclohexane	RT	+
Developer	RT	-
Diesel oil	RT	+
Distilled water	RT	+
	140	-
Electrolyte (dilute sulphuric acid)	RT	+
Epoxide resin	RT	+
Ethanol	RT	-
Fatty acids (greater than C 12)	104	+
Fish oil	RT	+
Fixer	RT	+
Formaldehyde, aqueous solution	RT	+
Formic acid 10%	RT	+
Fruit juices	RT	+
Gasoline, super and normal	RT	+
Glycerine	RT	+
Glycol (Ethylene glycol)	RT	+
Heating oil	RT	+
Humic acid	RT	+
Hydrochloric acid 10%	104	-
Hydrofluosilicic acid	68	-

+ = Resistant
- = Not Resistant

	Temperature in F	PRO-PLUS® GRP
Lactic acid, aqueous solution	RT	+
Hydrogen bromide	RT	-
Iron salts, aqueous solution	RT	+
Isopropyl alcohol (2-propanol)	RT	+
Jet fuel	RT	+
Linseed oil	RT	+
Lubricants	RT	+
Machine oil	RT	+
Magnesium salts, aqueous solution	RT	+
Maleic acid, aqueous solution	RT	+
Malic acid	86	+
Manganese salts, aqueous solution	RT	+
Margarine	RT	+
Milk	RT	+
Mineral oils	RT	+
Mineral water	RT	+
Nitric acid 10%	104	-
Octane	RT	+
	140	-
Oleic acid	RT	+
Oxalic acid, aqueous solution	RT	+
	140	-
Paraffin	RT	+
Perchloric acid	RT	-
Petroleum	RT	+
Petroleum ether	RT	+
Phosphoric acid 50%	104	-
Phosphoric acid 10%	RT	+
	140	-
Potash solution 2,5%	RT	-
Potassium permanganate 6%	140	-
Potassium salts, aqueous solution	RT	+
Ricinoleic acid	RT	+
Salicylic acid, aqueous solution	RT	+
Sea water	RT	+
	140	-
Silicone oil	RT	+
Sodium hydroxide 40%	104	-
Sodium salts, aqueous solution	RT	+
Soil, acidic and alkaline	RT	+
Solvents and cleaning solutions	RT	+
Succinic acid, aqueous solution	RT	+
Sugar	RT	+
Sulphuric acid 30%	RT	+
Tetrachlorethylene	RT	+
Thioglycollic	RT	-
Tin salts, aqueous solution	RT	+
Trichloroethylene	RT	-
Urea aqueous solution	RT	+
Washing agents, commercial, 5%	RT	+
Wine	RT	+
Zinc slats, aqueous solution	RT	+

RT = Room Temperature 78°F
GRP = Glass Fiber Reinforced Polyester

GRP is resistant when subjected over short periods to inorganic acids and subsequently rinsed with water. For any deviations with respect to temperature, concentrations, and purity of the listed media, technical advice is to be sought from your Josam representative or Josam directory

PRO-PLUS® FEATURES, BENEFITS AND OPTIONS

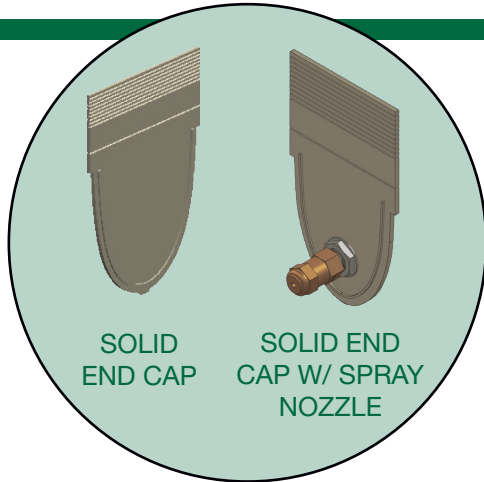

SOLID END CAP

SOLID END CAP W/ SPRAY NOZZLE

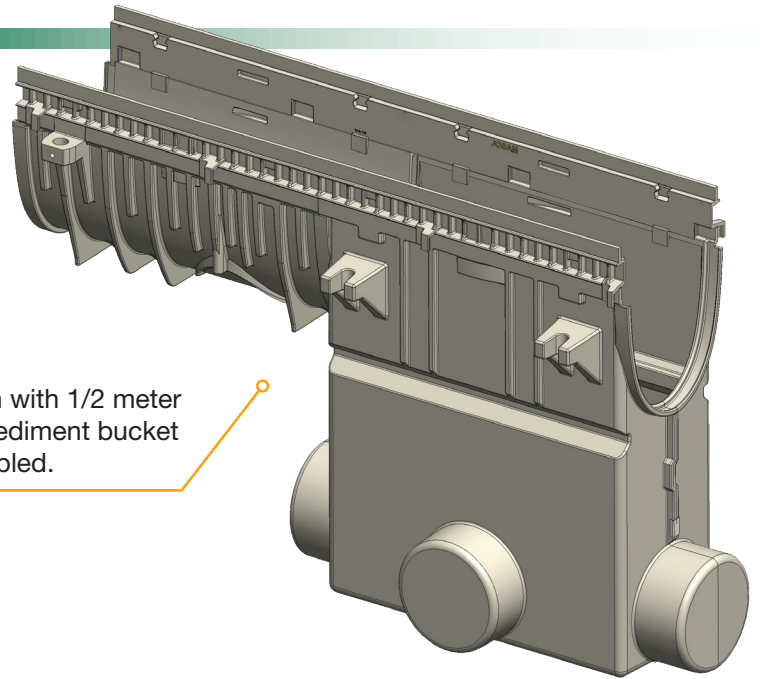

CATCH BASIN

Channel Width with 1/2 meter channel and sediment bucket factory assembled.

CHANNEL JOINT REBATE INSERT



The optimized CHANNEL shape ensures improved discharge rates even for low water levels and an enhanced self-cleaning effect.

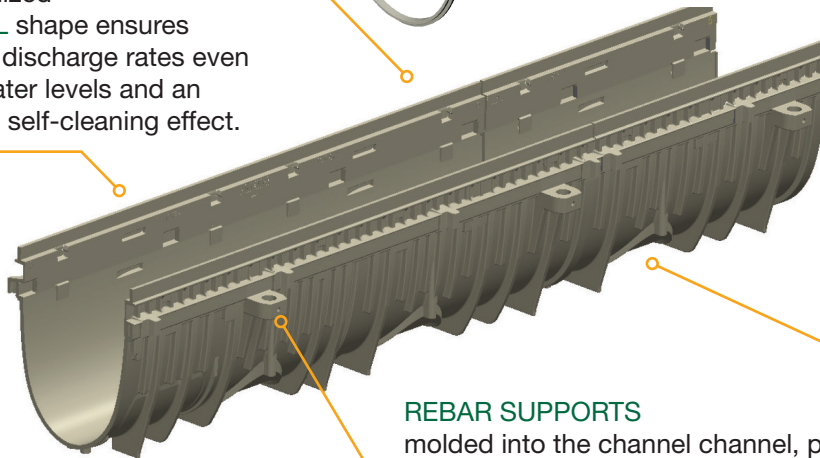

MALE/FEMALE JOINT

For ease of installation. Simply connect the channels.

REBAR SUPPORTS

molded into the channel channel, provides hanging bracket and securing screws.



DOME STRAINER for bottom outlet

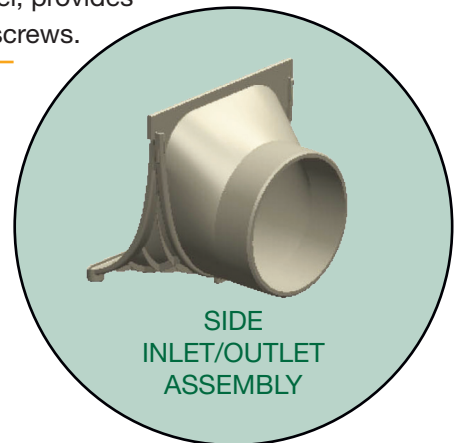

SIDE INLET/OUTLET ASSEMBLY

Refer to Pages 8-9 for part numbers when ordering.

PRO-PLUS® FEATURES, BENEFITS AND OPTIONS

PRO-PLUS®

Channels manufactured entirely in a specially developed SMC/GRP for a broad range of drainage solutions

The innovative PRO-SNAP® GRATE SECURING SYSTEM simplifies installation and maintenance

CORNER & T CHANNEL CONNECTOR

LARGE FINS molded into the entire exterior of the channel ensure permanent anchorage in concrete

END OUTLET/INLET

JOSAM offers GRP grates for a complete GRP Channel & Grate Trench Drain System

BOTTOM OUTLET CONNECTOR

BOTTOM OUTLETS located at every 1/2 meter

PRO-PLUS® OPTIONS

-EC	Solid End Cap	-OE4XL20	End Cap w/4" Outlet for 11-20	-SIO4	4" Side Outlet
-EC-HT	High Temp Solid End Cap	-OE4XL20-HT	High Temp End Cap w/4" Outlet for 11-20	-SIO6	6" Side Outlet
-EC-SS	Solid End Cap w/Stainless Steel Edge	-OE4XL20-SS	End Cap w/4" Outlet w/SS Edge for 11-20	-CT	Corner & Tee Connector
-ECXL20	Solid End Cap for 11-20	-OE6XL20	End Cap w/6" Outlet for 11-20	-BOS	Bottom Outlet Strainer
-ECXL20-HT	High Temp Solid End Cap for 11-20	-OE6XL20-HT	High Temp End Cap w/6" Outlet for 11-20	-DBS	Dome Bottom Strainer
-ECXL20-SS	Solid End Cap for 11-20 w/ SS Edge	-OE6XL20-SS	End Cap w/6" Outlet & SS Edge	-BS	Channel Bracket Support
-EC-SN	Solid End Cap w/ Spray Nozzle	-OB4	4" Bottom Outlet	-BSW	Outlet End Bracket Support
-FD	30004 Body Connection	-OB4-HT	High Temp 4" Bottom Outlet	-BSC	Male-Male Bracket Conn Support
-OES	End Outlet Strainer	-OB6	6" Bottom Outlet	-BSCB	Bracket Support for CB Connection
-OE4	End Cap w/4" Outlet	-OB6-HT	High Temp 6" Bottom Outlet	-RI	Rebate Insert

PRO-PLUS® FEATURES, BENEFITS AND OPTIONS

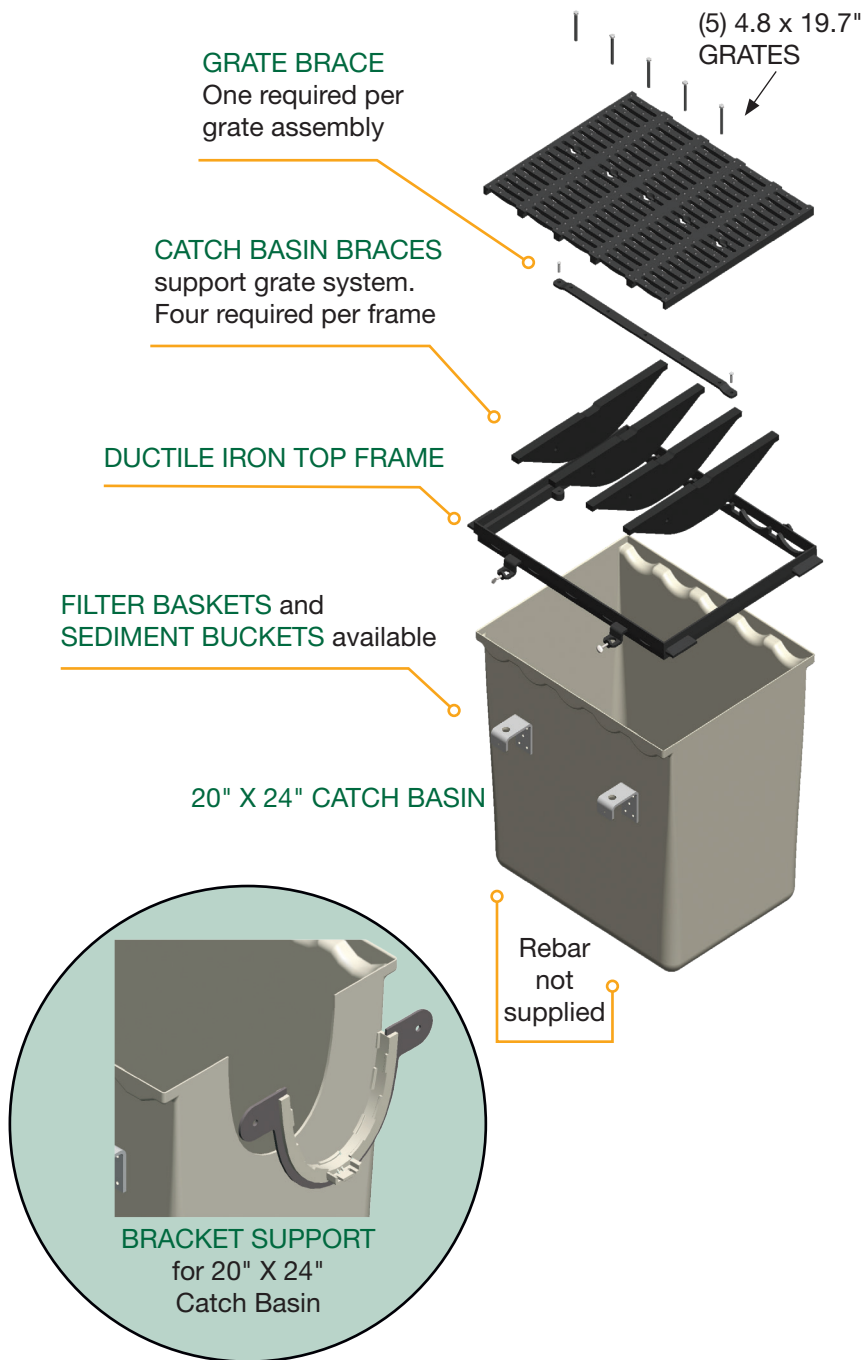

OPTION - 360180
Class E Ductile Iron Frame and Grate for 20" x 24" Catch Basin

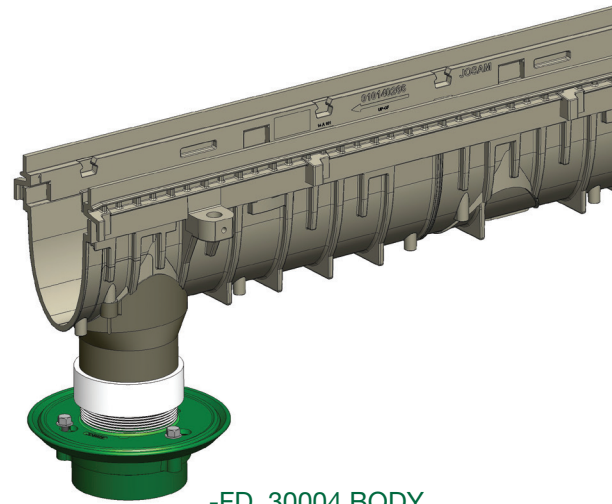
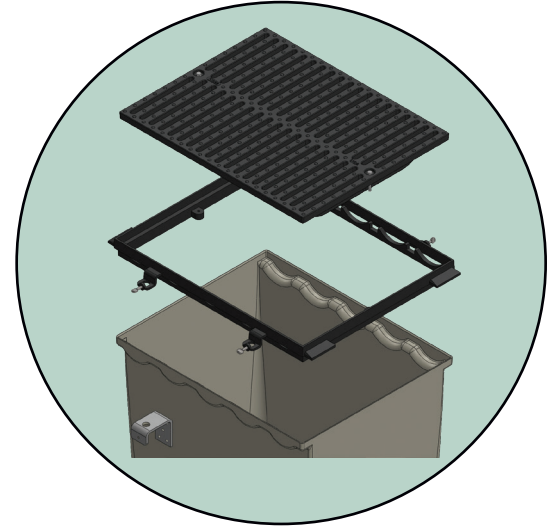

-FD 30004 BODY CONNECTION
(specify -X, -Y, -Z, or -T)
includes bottom outlet and PVC Adapter

-RI-HT	High Temp Rebate Insert	-350151	20"x24"x24" Deep Catch Basin	-360141	100 Series Locking Bar w/Hex Head Bolt
-SSE	Stainless Steel Edge	-350158	Ductile Iron CB Top Frame for Catch Basin	-360141-FH	100 Series Locking Bar w/Flat Head Screw
-VP	Vandal Proof Grate	-350158-1	CB Top Frame Lock Bar for Catch Basin	-360142	200 Series Locking Bar w/Hex Head Bolt
-GALV	Galvanized Cast Iron Parts	-350158-2	CB Top Frame Supports for Catch Basin	-360142-FH	200 Series Locking Bar w/Flat Head Screw
-MMR-T	Male-Male Reverse	-350154	4" PVC Outlet Connector for CB	-360143	Set of 4 bolts for bolt down grates
-MMR-T-SS	Male-Male Reverse, SS	-350153	6" PVC Outlet Connector for CB	-360180	Class E Ductile Iron Frame and Grate for 20" x 24" Catch Basin
-MMS	Male-Male Standard	-350152	8" PVC Outlet Connector for CB		
-MMS-SS	Male-Male Standard SS	-SB	Catch Basin - Channel Width		
-152441T	100 Ductile Iron Rail 19.7"	-350159	CB Split Filter Basket		
-152442T	200 Ductile Iron Rail 19.7"	-350159-SB	CB Split Sediment Bucket		

PRO-PLUS® CHANNELS

100 SERIES 39.4" CHANNEL			
PRODUCT CODE	DESCRIPTION	DEPTH	
		START/INCHES (FEMALE END)	END/INCHES (MALE END)
100C	Neutral Channel	6.2	6.2
100C01	Sloped Channel	7.5	7.7
100C02	Sloped Channel	7.7	7.9
100C03	Sloped Channel	7.9	8.1
100C04	Sloped Channel	8.1	8.3
100C05	Sloped Channel	8.3	8.5
100C05N	Neutral Channel	8.5	8.5
100C06	Sloped Channel	8.5	8.7
100C07	Sloped Channel	8.7	8.9
100C08	Sloped Channel	8.9	9.1
100C09	Sloped Channel	9.1	9.3
100C10	Sloped Channel	9.3	9.5
100C11	Sloped Channel	9.5	9.7
100C12	Sloped Channel	9.7	9.9
100C13	Sloped Channel	9.9	10.1
100C14	Sloped Channel	10.1	10.3
100C15	Sloped Channel	10.3	10.5
100C15N	Neutral Channel	10.5	10.5
100C16	Sloped Channel	10.5	10.7
100C17	Sloped Channel	10.7	10.9
100C18	Sloped Channel	10.9	11.1
100C19	Sloped Channel	11.1	11.3
100C20	Sloped Channel	11.3	11.5

• 19.7" (100 Series) sections available upon request

200 SERIES 39.4" CHANNEL			
PRODUCT CODE	DESCRIPTION	DEPTH	
		START/INCHES (FEMALE END)	END/INCHES (MALE END)
200C	Neutral Channel	9.5	9.5
200C01	Sloped Channel	10.8	11.0
200C02	Sloped Channel	11.0	11.2
200C03	Sloped Channel	11.2	11.4
200C04	Sloped Channel	11.4	11.6
200C05	Sloped Channel	11.6	11.8
200C05N	Neutral Channel	11.8	11.8
200C06	Sloped Channel	11.8	12.0
200C07	Sloped Channel	12.0	12.2
200C08	Sloped Channel	12.2	12.4
200C09	Sloped Channel	12.4	12.6
200C10	Sloped Channel	12.6	12.8
200C11	Sloped Channel	12.8	13.0
200C12	Sloped Channel	13.0	13.2
200C13	Sloped Channel	13.2	13.4
200C14	Sloped Channel	13.4	13.6
200C15	Sloped Channel	13.6	13.8
200C15N	Neutral Channel	13.8	13.8
200C16	Sloped Channel	13.8	14.0
200C17	Sloped Channel	14.0	14.2
200C18	Sloped Channel	14.2	14.4
200C19	Sloped Channel	14.4	14.6
200C20	Sloped Channel	14.6	14.8

• 19.7" (200 Series) sections available upon request

Nominal interior widths of 4" and 8" | 39.4" and 19.7" lengths

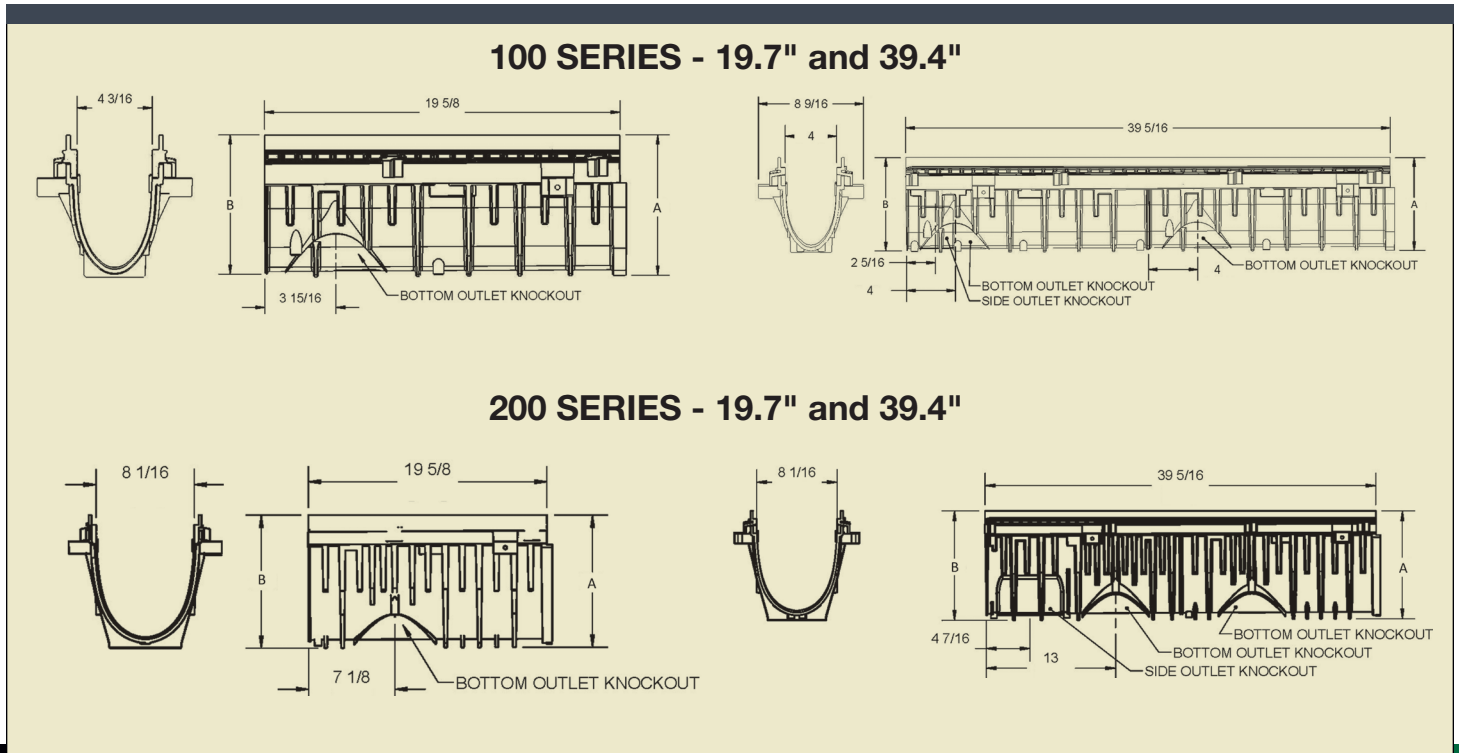

PRO-SNAP® – The innovative grate securing system without bolts

- Innovative 4-point locking inside the channel body for a solid and secure fit, without any loose or rattling parts
- Protection against longitudinal displacement of grate covers
- Long service life—has no moving parts or parts subject to wear
- No reduction of the discharge cross section, as the complete channel cross section remains unobstructed
- Simple and fast insertion and removal of grates with a single hand movement—without the need for special tools
- Particularly smooth and quiet, thanks to the sound-absorbing securing system

The PRO-SNAP® system constitutes another innovation for securing grates. The whole process has never been as fast or as simple. All of the different grate types can be secured and removed quickly and easily with a single hand movement, without the use of bolts or special tools.

The sturdy 4-point locking system prevents loose or rattling grates and offers rugged protection against longitudinal displacement. The channel cross-section remains completely unobstructed so that discharge rates remain unaffected.

PRO-SNAP® is also aesthetically pleasing to satisfy architectural designs. The PRO-SNAP® closure device fitting flush with the channel upper surface results in an attractive drainage solution.

PRO-SNAP® Grate with clip installed, clicks down into the channel

SNAP INTO PLACE!

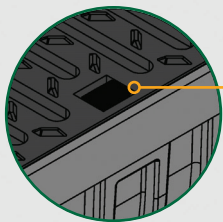





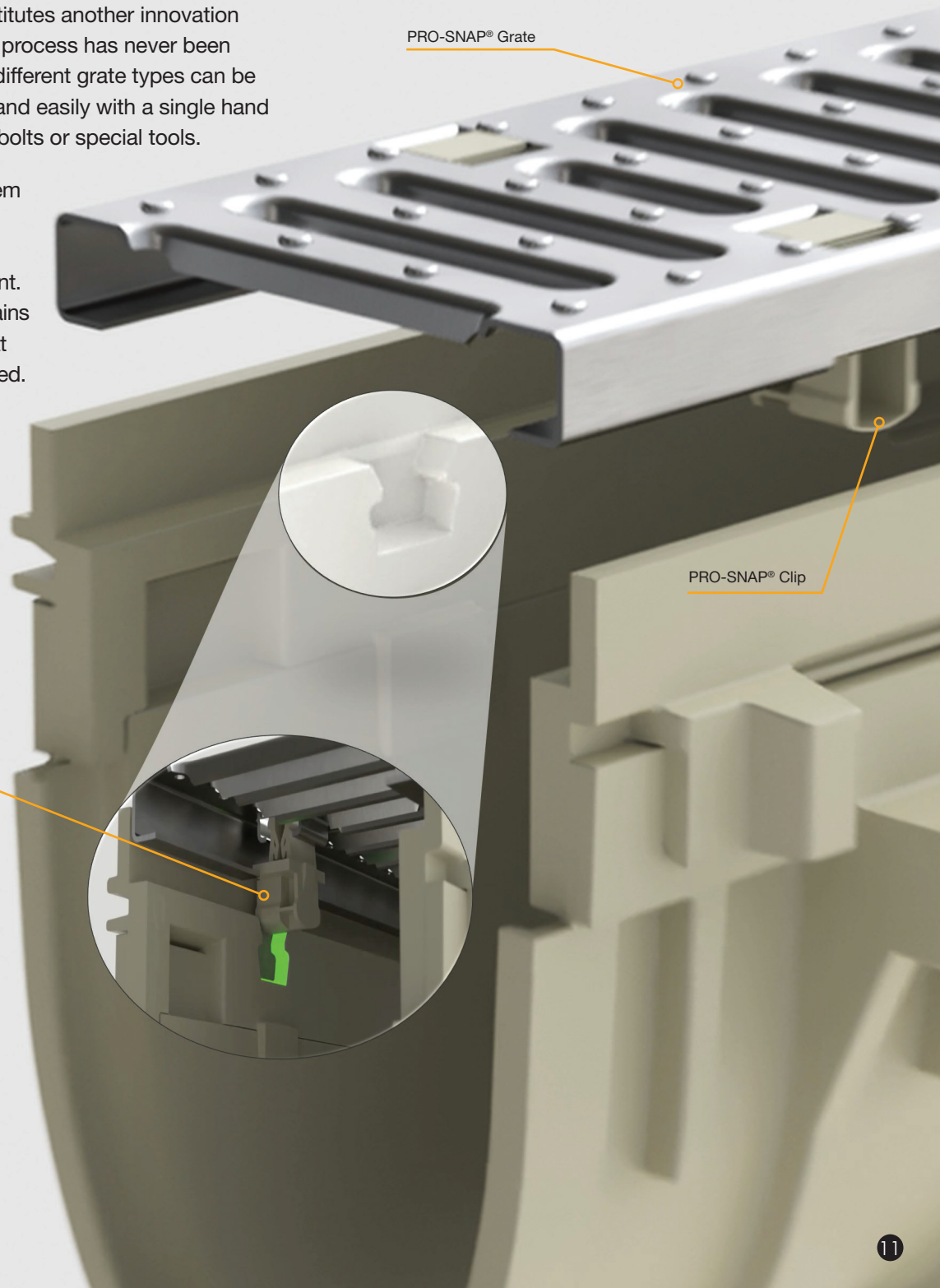







Grate Secured to Channel

DONE!

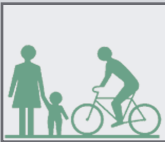

GRATE OPTIONS

Type of Grates					
Stainless Steel Grates	Ductile Iron Grates	Galvanized Steel Grates	GRP Grates	HDPE Grates	Vinylester Bar Grates
					
Available in Perforated, Slotted, Mesh, Bar, and Decorative. ADA/HP Compliant. For Load Classes A-E.	Available in Slotted and Longitudinal Slotted. (Powder Coated) ADA/HP Compliant. For Load Classes C-F.	Available in Perforated and Slotted. ADA/HP Compliant. For Load Classes A-C.	Available in Slotted. ADA/HP Compliant. For Load Classes A-C.	HDPE available in Perforated. ADA/HP Compliant. For Load Class A.	Vinylester Bar. ADA/HP Compliant. For Load Classes A.

Load Classes					
<p>A 15 3,500 lbs., 70 PSI</p>  <ul style="list-style-type: none"> • Pedestrians • Bicycles • Parks 	<p>B 125 28,100 lbs., 580 PSI</p>  <ul style="list-style-type: none"> • Footpaths • Driveways • Parking Garages 	<p>C 250 56,000 lbs., 1,162 PSI</p>  <ul style="list-style-type: none"> • Roadside • Warehouses • Pneumatic tire forklifts • Tractor trailers 	<p>D 400* 90,000 lbs., 1,859 PSI</p>  <ul style="list-style-type: none"> • Public roads • Highways • Parking lots <p>*Not across the road</p>	<p>E600 135,000 lbs., 2,788 PSI</p>  <ul style="list-style-type: none"> • Industrial areas • Hard wheel forklifts (must use DI Rail) • Heavy commercial vehicles 	<p>F 900 200,000 lbs., 4,182 PSI</p>  <ul style="list-style-type: none"> • Airports • Freight/Cargo Terminals • Heavy Industrial Vehicles

Recommended concrete surround

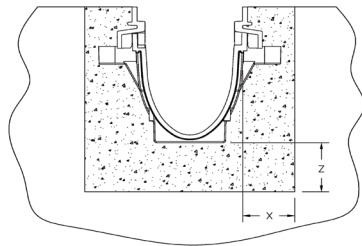

	Load Class					
	A	B	C	D	E	F
X (in)	>3	>4	>6	>8	>8	>10
Z (in)	>3	>4	>6	>8	>8	>10

DUCTILE IRON RAILS

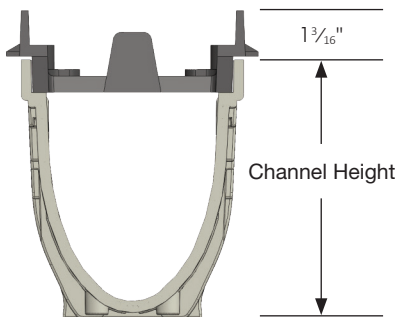

LOCKING SYSTEM
4-point bolt and center bar locking grates

DI RAILS

ANCHOR TABS

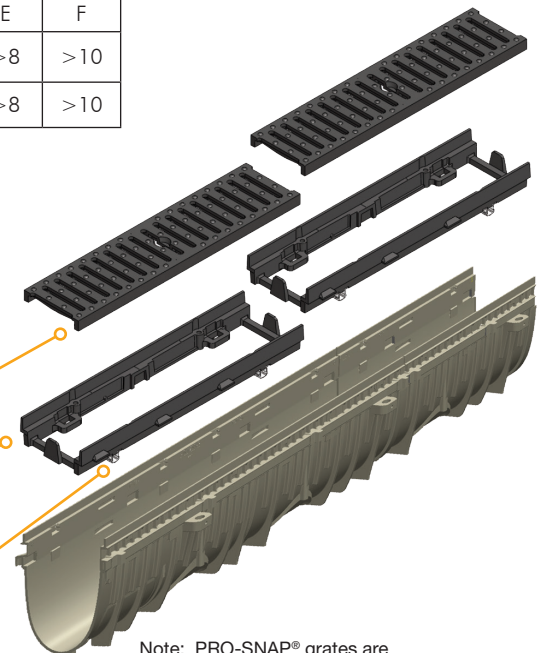

Note: PRO-SNAP® grates are not compatible with DI rails

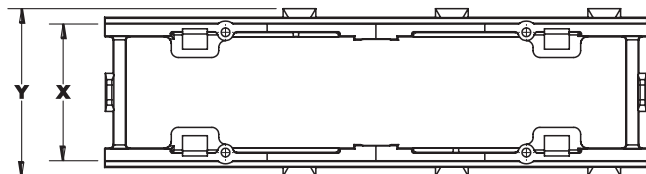

Channel Size	Rail Part Number	"X" Dimension	"Y" Dimension
100	100-RAIL	4.94	6.06
200	200-RAIL	8.88	10.00

Josam's various grate designs and material alternatives such as slotted and mesh grates in galvanized steel and stainless steel, non-slip swimming pool grates in HDPE, and slotted grates in ductile iron make the Josam PRO-SNAP® channel system the ideal choice for most applications. Available in nominal interior channel widths of 4" and 8", for the best possible connection.





100 Series PRO-SNAP® Grates								
	PRODUCT DESCRIPTION	PART NO.	DIM. (IN.)	SLOT WIDTH (IN.)	LBS/UNIT	EN	H2O	ADA/Heel Proof
	Galvanized Steel Slotted Grate	100-GSS-A-PS	4.8 x 19.7	0.31	2.5	A	N	ADA/HP
	Stainless Steel Slotted Grate	100-SSS-A-PS	4.8 x 19.7	0.31	2.6	A	N	ADA/HP
	HDPE Perforated Grate	100-HDPE-A-PS	4.8 x 19.7	0.25	1.1	A	N	ADA/HP
	Stainless Steel Slotted Grate	100-SSS-C-PS	4.8 x 19.7	0.31	4.8	C	N	ADA/HP
	Ductile Iron Slotted Grate	100-DIS-C-PS/DC	4.8 x 19.7	0.31	8.9	C	Y	ADA/HP
	Galvanized Steel Slotted Grate	100-GSS-C-PS	4.8 x 19.7	0.31	4.7	C	N	ADA/HP
	Ductile Iron Slotted Grate	100-DIS-F-PS/DC	4.8 x 19.7	0.50	12.0	F	Y	ADA
200 Series PRO-SNAP® Grates								
	PRODUCT DESCRIPTION	PART NO.	DIM. (IN.)	SLOT WIDTH (IN.)	LBS/UNIT	EN	H2O	ADA/Heel Proof
	Ductile Iron Slotted Grate	200-DIS-C-PS	8.8 x 19.7	0.31	15.8	C	Y	ADA/HP
	DI Longitudinal Slotted Grate	200-DIL-E-PS-DC	8.8 x 19.7	0.31	29.5	E	Y	ADA/HP
	Ductile Iron Slotted Grate	200-DIS-F-PS	8.8 x 19.7	0.50	29.2	F	Y	ADA

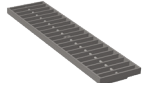

When operating hard wheel forklift or scissor lift, Class E or above grates must be used with a DI Rail. PRO-SNAP® Grates Cannot Be Used With DI Rail. All ductile iron grates come standard with epoxy coating finish.

PRO-PLUS® 100 SERIES GRATES

100 Series Grates										
	PRODUCT DESCRIPTION	PART NO.	DIM. (IN.)	LBS/ UNIT	SLOT WIDTH (IN.)	LOCKING DEVICE		EN	H2O	ADA/Heel Proof
						Type	Part No.			
	Galvanized Steel Slotted Grate	100-GSS-A	4.8 x 19.7	2.5	0.31	LB	360141	A	N	ADA/HP
	Galvanized Steel Perforated Grate	100-GSP-A	4.8 x 19.7	2.8	0.25	LB	360141-FH	A	N	ADA/HP
	Stainless Steel Slotted Grate	100-SSS-A	4.8 x 19.7	2.6	0.31	LB	360141	A	N	ADA/HP
	Stainless Steel Perforated Grate	100-SSP-A	4.8 x 19.7	2.8	0.25	LB	360141-FH	A	N	ADA/HP
	Vinylester Bar Grate	100-VB-A-DC	4.8 x 19.7	2.2	0.50	LB	360141-FH	A	N	ADA/HP
	GRP Slotted Grate	100-GRP-A	4.8 x 19.7	3.9	0.31	LB BD	360141 360143	A	N	ADA/HP
	Decorative Stainless Steel Grate	100-SSWW-A	4.8 x 19.7	3.6	0.19	LB	360141-FH	A	N	ADA/HP
	Ductile Iron Slotted Grate	100-DIS-C	4.8 x 19.7	8.9	0.31	LB BD	360141 360143	C	Y	ADA/HP
	Cast Iron Solid Cover	100-CIS-C-DC	4.8 x 19.7	10.9	N/A	LB	360141	C	Y	N/A
	Galvanized Steel Perforated Grate	100-GSP-C	4.8 x 19.7	5.0	0.25	LB	360141-FH	C	N	ADA/HP
	Stainless Steel Mesh Grate	100-SSM-C	4.8 x 19.7	4.3	1.1	LB	360141-FH	C	N	N/A
	Stainless Steel Slotted Grate	100-SSS-C	4.8 x 19.7	4.8	0.31	LB	360141	C	N	ADA/HP
	Stainless Steel Perforated Grate	100-SSP-C	4.8 x 19.7	5.0	0.25	LB	360141-FH	C	N	ADA/HP
	DI Longitudinal Slotted Grate	100-DIL-C-DC	4.8 x 19.7	11.8	0.19	LB	360141	C	Y	ADA/HP
	Galvanized Steel Slotted Grate	100-GSS-C	4.8 x 19.7	4.7	0.31	LB	360141	C	N	ADA/HP
	Decorative Stainless Steel Grate	100-SSWW-C	4.8 x 19.7	4.6	0.19	LB	360141-FH	C	N	ADA/HP
	GRP Slotted Grate	100-GRP-C	4.8 x 19.7	3.9	0.31	LB BD	360141 360143	C	N	ADA/HP

PRO-PLUS® 100 & 200 SERIES GRATES

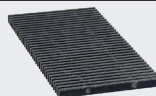
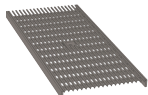
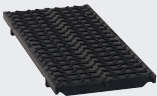
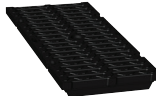
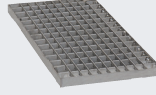
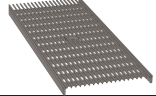
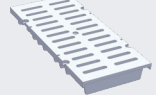
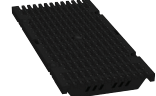
100 Series Grates										
	PRODUCT DESCRIPTION	PART NO.	DIM. (IN.)	LBS/ UNIT	SLOT WIDTH (IN.)	LOCKING DEVICE		EN	H20	ADA/ Heel Proof
						Type	Part No.			
	Stainless Steel Bar Grate	100-SSB-E	4.8 x 19.7	14.5	0.75	LB	360141-FH	E	Y	ADA
	Ductile Iron Slotted Grate	100-DIS-E-DC	4.8 x 19.7	14.5	0.31	LB	360141	E	Y	ADA/HP
	Ductile Iron Slotted Grate	100-DIS-F	4.8 x 19.7	12.1	0.50	LB BD	360141 360143	F	Y	ADA
	Top Slot SS Frame	100-TS	4.8 x 19.7	5.4	0.50	NA	NA	NA	NA	ADA
		100-TS-HP	4.8 x 19.7	5.2	0.31	NA	NA	NA	NA	ADA/HP

200 Series Grates										
	PRODUCT DESCRIPTION	PART NO.	DIM. (IN.)	LBS/ UNIT	SLOT WIDTH (IN.)	LOCKING DEVICE		EN	H20	ADA/ Heel Proof
						Type	Part No.			
	Vinylester Bar Grate	200-VB-A-DC	8.8 x 19.7	3.8	0.31	LB	360142-FH	A	N	ADA/HP
	Decorative Stainless Steel Grate	200-SSWW-A	8.8 x 19.7	5.9	0.25	LB	360142-FH	A	N	ADA/HP
	Ductile Iron Slotted Grate	200-DIS-C	8.8 x 19.7	15.9	0.31	LB BD	360142 360143	C	Y	ADA/HP
	GRP Slotted Grate	200-GRP-C	8.8 x 19.7	11.8	0.31	LB BD	360142 360143	C	Y	ADA/HP
	Stainless Steel Mesh Grate	200-SSM-C	8.8 x 19.7	10.5	1.2	LB	360142-FH	C	Y	N/A
	Decorative Stainless Steel Grate	200-SSWW-C	8.8 x 19.7	8.4	0.25	LB	360142-FH	C	N	ADA/HP
	Stainless Steel Slotted Grate	200-SSS-E	8.8 x 19.7	26.0	0.50	LB BD	360142 360143	E	Y	ADA
	DI Longitudinal Slotted Grate	200-DIL-E-DC	8.8 x 19.7	29.6	0.31	LB BD	360142 360143	E	Y	ADA/HP
	Ductile Iron Slotted Grate	200-DIS-F/DC	8.8 x 19.7	29.3	0.50	LB BD	360142 360143	E/F	Y	ADA

When operating hard wheel forklift or scissor lift, Class E or above grates must be used with a DI Rail. Decorative Grates Available Upon Request. All ductile iron grates come standard with epoxy coating finish.



A **WATTS** Brand

T: (800) 365-6726 • Josam.com