

SPECIFICATION:

JOSAM SERIES FD-210-4CP-SQ FLOOR DRAIN WITH PVC BODY, INVERTIBLE CLAMP COLLAR WITH DRAINAGE SLOTS, AND 4" SQUARE ADJUSTABLE CHROME-PLATED BRASS STRAINER.

FLOOR DRAIN

PVC

FD-210-4CP-SQ

SERIES

GRATE FREE AREA: 3.75 in²
MEETS ADA AND HEEL-PROOF REQS.

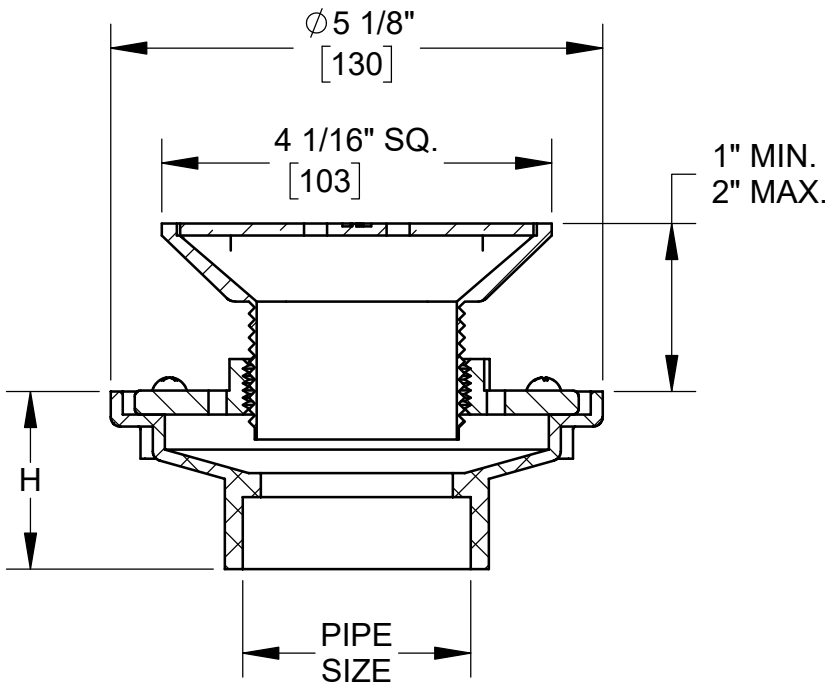
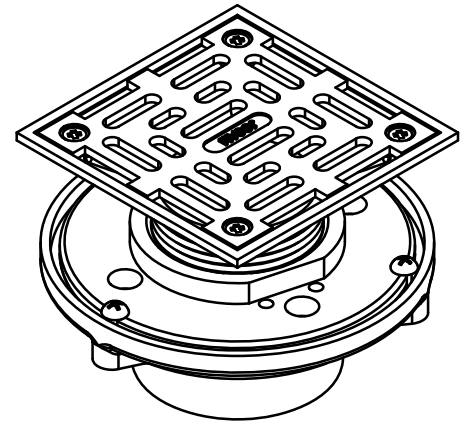
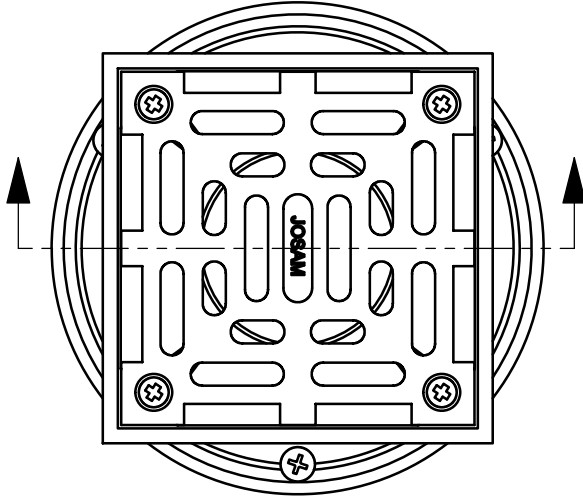

MODEL	PIPE SIZE	H
FD-212	2"	2-1/8
FD-213	3"	2-3/4
FD-214	4"	2-3/4

WARNING: Cancer and Reproductive Harm - www.P65Warnings.ca.gov

DATE OF LAST CHANGE: 06/26/18

DIMENSIONS ARE SUBJECT TO MANUFACTURERS TOLERANCES AND CHANGE WITHOUT NOTICE. WE CAN ASSUME NO RESPONSIBILITY FOR USE OF SUPERSEDED OR VOID DATA.



MICHIGAN CITY, INDIANA

NOTES