

SPECIFICATION:

JOSAM 100-SSP-A STAINLESS STEEL PERFORATED GRATE WITH CENTER HOLE FOR LOCKING BAR SECUREMENT. DESIGNED TO FIT PRO-PLUS™ 100 SIZE CHANNEL. MEETS ADA AND HEELPROOF REQUIREMENTS.

TRENCH DRAIN GRATE

PRO-PLUS™ 100

SERIES **100-SSP-A**

LOAD RATINGS EN/DIN: A H20: N

NOTE:
FREE AREA IS 18.7 SQ. IN. PER GRATE

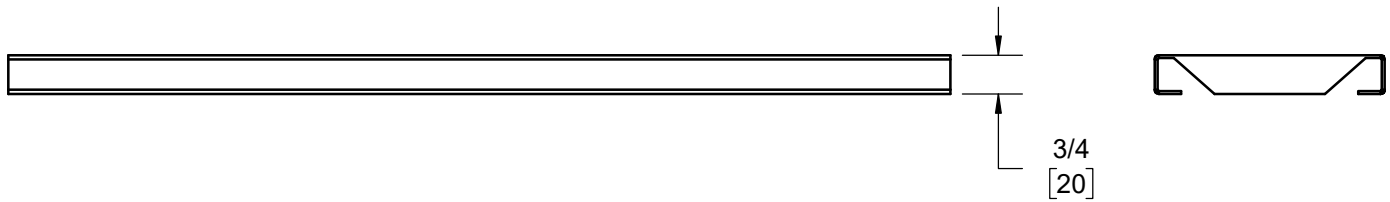
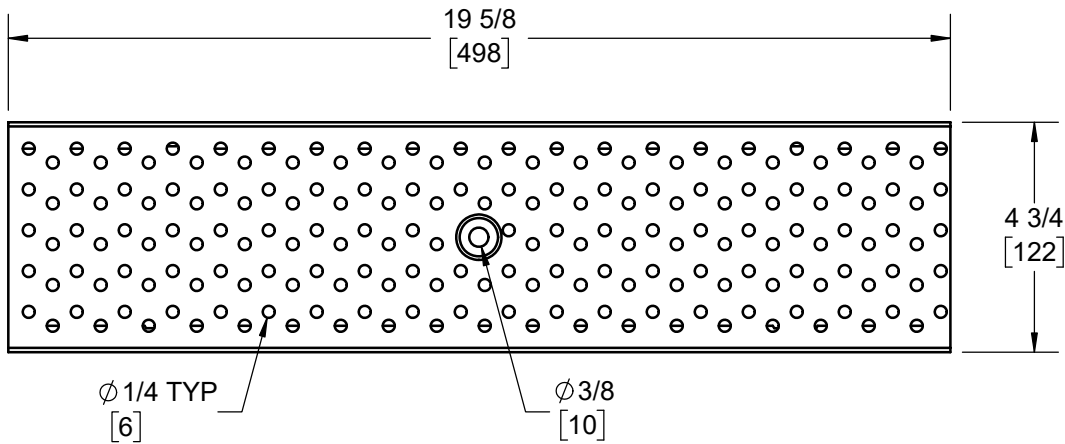
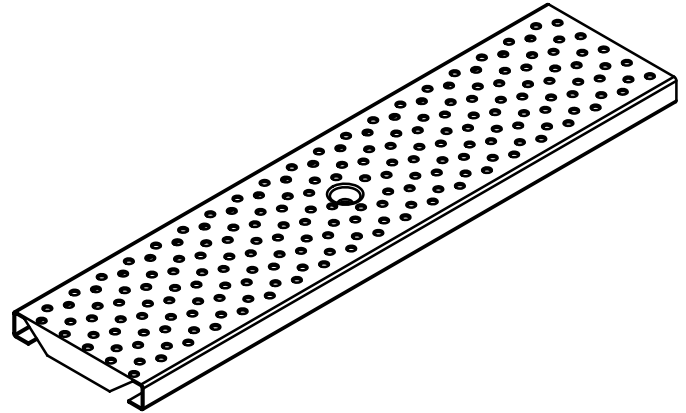

LOCKING BAR (ORDER SEPERATELY) 360141-FH

WARNING: Cancer and Reproductive Harm - www.P65Warnings.ca.gov

DATE OF LAST CHANGE: 6/01/23 JTJ
DIMENSIONS ARE SUBJECT TO MANUFACTURERS TOLERANCES AND CHANGE WITHOUT NOTICE. WE CAN ASSUME NO RESPONSIBILITY FOR USE OF SUPERSEDED OR VOID DATA.

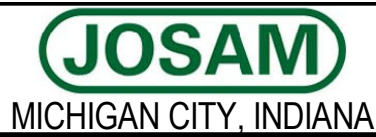

NOTES