

**SPECIFICATION:**

MEA JOSAM REINFORCED GALVANIZED STEEL TRENCH GRATE WITH CLIPFIX LOCKING DEVICE FOR LOADING CLASS C250

**TRENCHGRATE**

MEA JOSAM SERIES

SERIES **152713 / 152718**

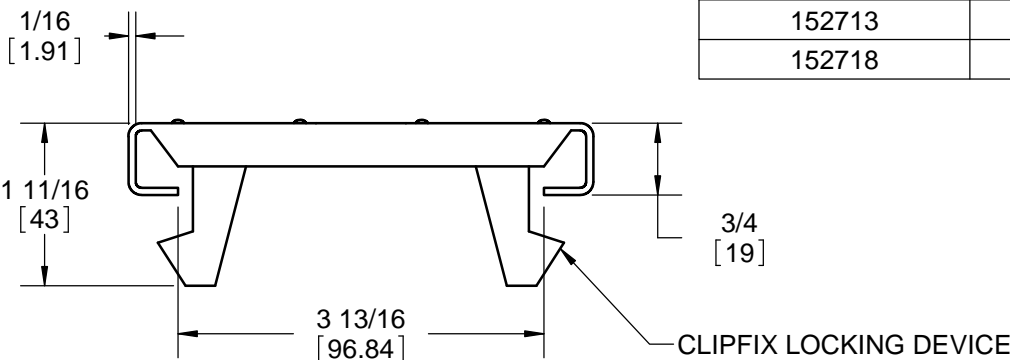
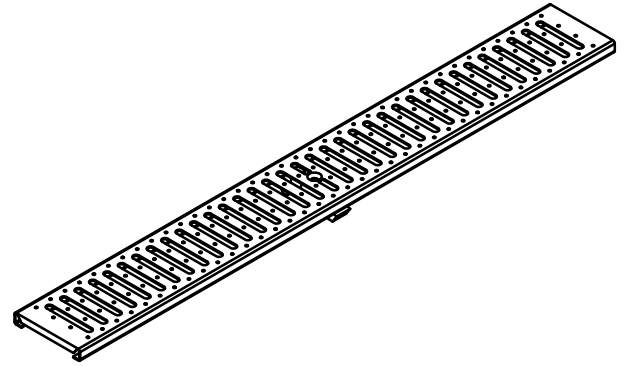
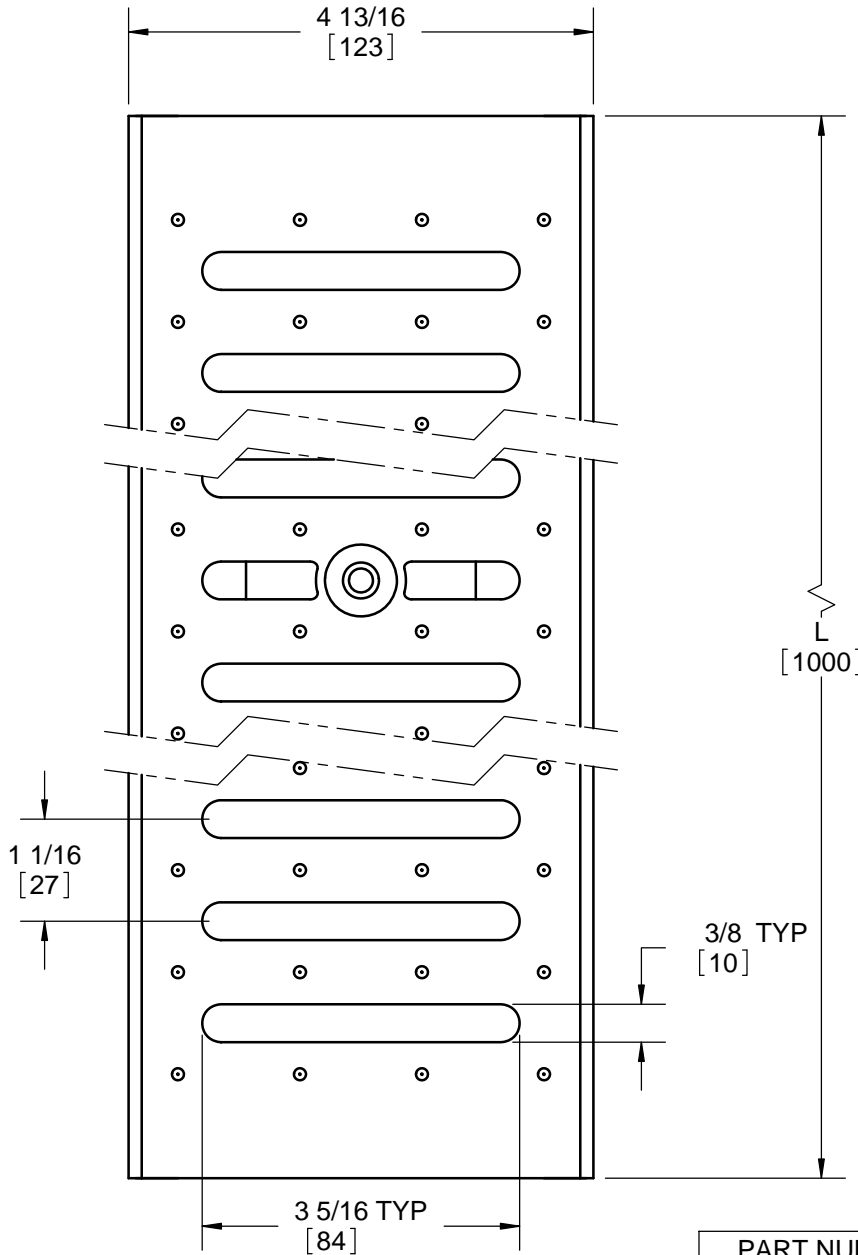

PART NUMBER	"L" DIM	FREE AREA
152713	39.4"	43.4 SQ. IN.
152718	19.7"	21.7 SQ. IN.

WARNING: Cancer and Reproductive Harm - www.P65Warnings.ca.gov

DATE OF LAST CHANGE: 6/08/18

DIMENSIONS ARE SUBJECT TO MANUFACTURERS TOLERANCES AND CHANGE WITHOUT NOTICE. WE CAN ASSUME NO RESPONSIBILITY FOR USE OF SUPERSEDED OR VOID DATA.

**JOSAM**  
MICHIGAN CITY, INDIANA

NOTES