

**SPECIFICATION:**

JOSAM 32100 SERIES COATED CAST IRON FLOOR DRAIN, TWO-PIECE BODY WITH DOUBLE DRAINAGE FLANGE, WEJLOC® NON-PUNCTURING FLASHING COLLAR, WEEPHOLES, BOTTOM OUTLET, ROUND TOP, MEDIUM-DUTY LOOSE-SET ANTI-TILTING SUPER-FLO® GRATE WITH PERIMETER DRAINAGE SLOTS.

**FLOOR DRAIN**  
9" ROUND TOP, SUPER-FLO®

SERIES **32100**

GRATE FREE AREA: 27 IN<sup>2</sup>  
SLOT WIDTH 3/8" (MEETS ADA)

-1, -2 & (-SS-LAM FOR -TG ONLY)  
SLOT WIDTH = 1/4" - HEEL PROOF  
F.A. = 25 IN<sup>2</sup>

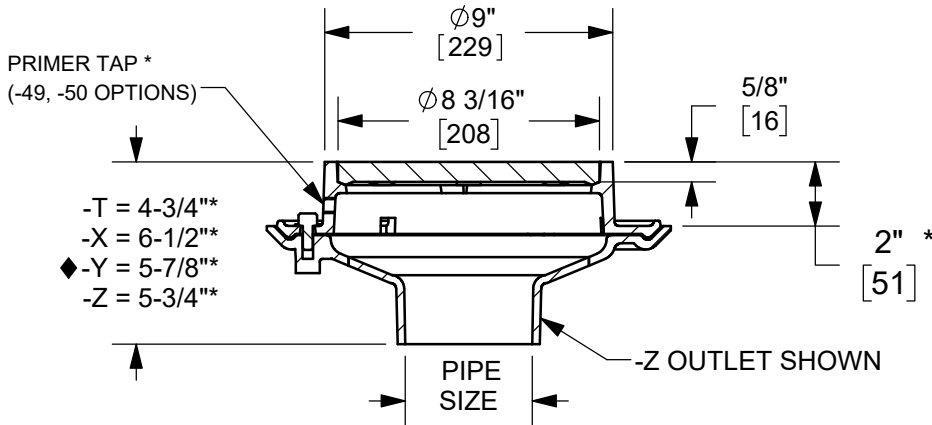
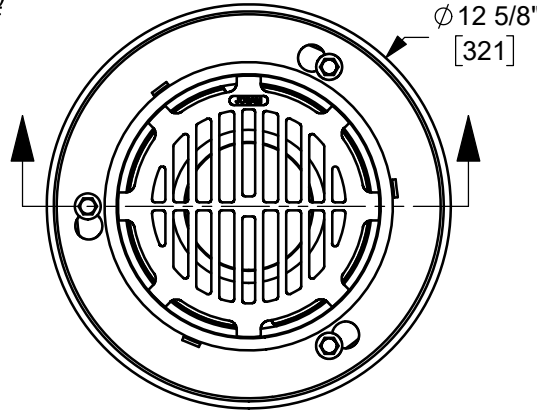
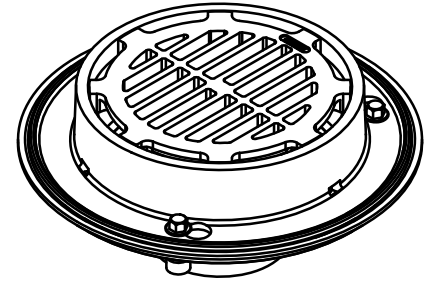

◆ GASKET CONFORMS WITH ASTM-C564

\*ADD 1/4" WHEN FURNISHED WITH NIKALOY OR BRONZE TOP (-1 OR -2)

\*\* ADD 1/4" WHEN FURNISHED WITH STAINLESS STEEL TOP (-SS-LAM FOR -TG ONLY)

\* FOR TRAP PRIMER CONNECTION BELOW DRAIN, USE 88400 OR 88450 ADAPTER.

2"	PIPE SIZE	-39	SOLID CAST IRON COVER
3"	PIPE SIZE	-VP	SECURED GRATE, VANDAL-PROOF SCREWS
4"	PIPE SIZE	-ARE	ACID-RESISTING EPOXY
6"	PIPE SIZE, NO-HUB -SEE SEPARATE SUBMITTAL 32106	-44	FIXED EXTENSION COLLAR, CAST IRON ( SPEC. HT. ) 2" STD.
-AE	LEVELEZE ADJUSTABLE EXTENSION	-44-92	FIXED EXTENSION COLLAR, GALVANIZED ( SPEC. HT. ) 2" STD.
-81	SLOTTED CAST IRON BUCKET	-49	3/4" PRIMER TAP
-TG	TRACTOR GRATE **	-50	1/2" PRIMER TAP
-LC1	LOCKING COVER, SATIN FINISH NIKALOY	-84	STAINLESS STEEL MESH BUCKET LINER
-LC2	LOCKING COVER, SATIN FINISH BRONZE	-88	SUPPLEMENTARY STRAINER
-1	SATIN FINISH NIKALOY TOP - HEEL PROOF	-92	GALVANIZED CAST IRON PARTS
-2	SATIN FINISH BRONZE TOP - HEEL PROOF	-66	NO-HUB SIDE OUTLET
-7	DUCTILE IRON GRATE	-HP	HEEL-PROOF GRATE, CI, 5/16" SLOT WIDTH, 25 SQ IN FREE AREA
-11	EXTRA-HEAVY DUTY GRATE, CAST IRON	-TSI	TRAP SEAL INSERT
-13	DOME GRATE, CAST IRON	-T	THREADED OUTLET
-13-1	DOME GRATE, NIKALOY	-X	INSIDE CAULK OUTLET
-13-2	DOME GRATE, BRONZE	-Y	HUB OUTLET WITH GASKET
-15	CHAINED GRATE	-Z	NO-HUB OUTLET
-SS-LAM	STAINLESS STEEL - LAMINATE - HEEL PROOF**		

DATE OF LAST CHANGE: 03/12/19

DIMENSIONS ARE SUBJECT TO MANUFACTURERS TOLERANCES AND CHANGE WITHOUT NOTICE. WE CAN ASSUME NO RESPONSIBILITY FOR USE OF SUPERSEDED OR VOID DATA.

**JOSAM**

MICHIGAN CITY, INDIANA

NOTES