

SPECIFICATION:

17720-66-M1806 SERIES FLOOR MOUNTED CARRIER WITH HANGER PLATE, ADJUSTABLE HEADERS AND WELDED FOOT STRUCTURAL UPRIGHTS. FOR WHITEHALL WH3778 LAVATORY.

**LAVATORY CARRIER
SINGLE STATION**

SERIES **17720-66-M1806**

JOSAM RECOMMENDS - FEET BE SECURED TO FLOOR WITH 1/2" BOLTS AND ANCHORS BY OTHERS

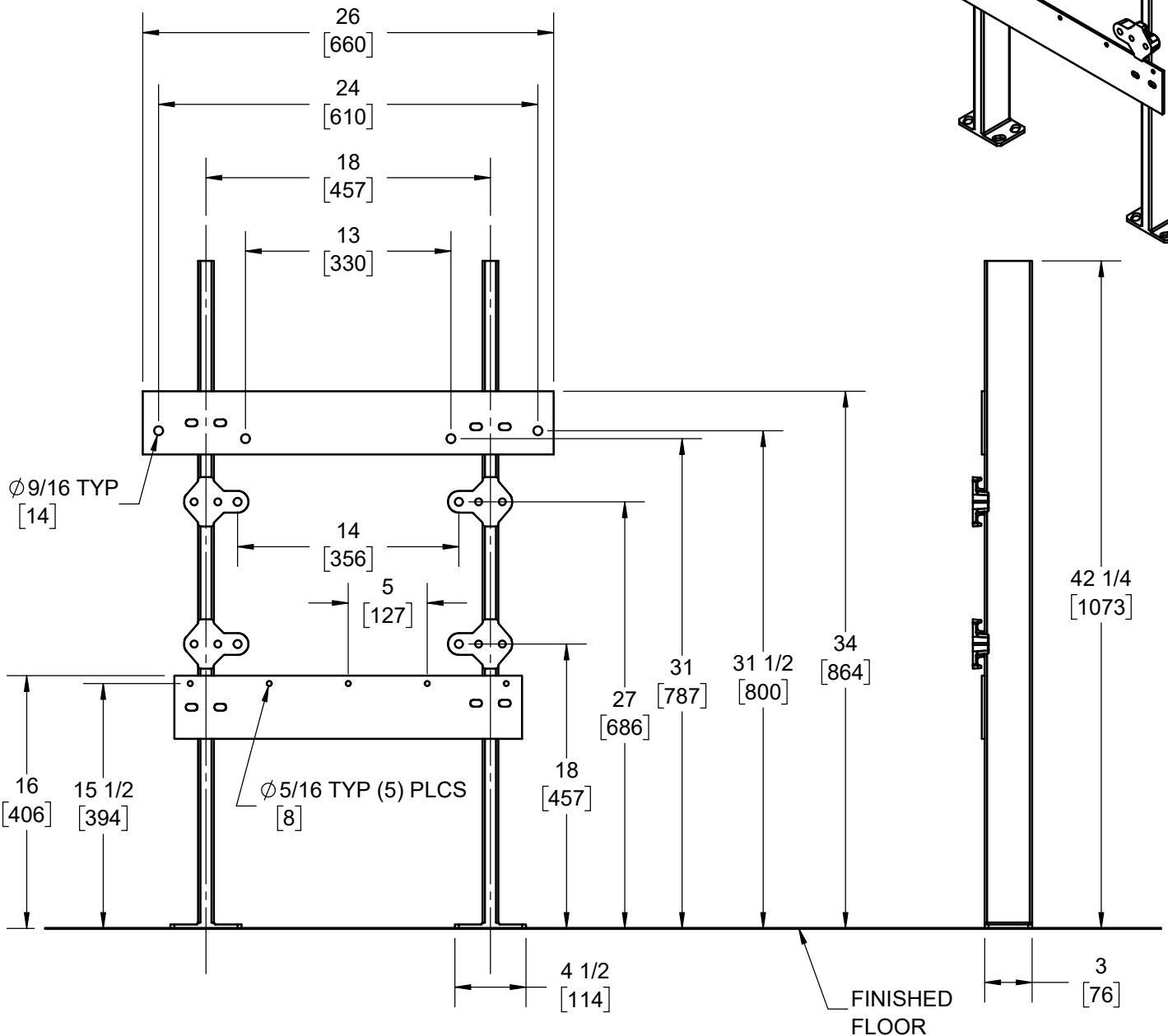
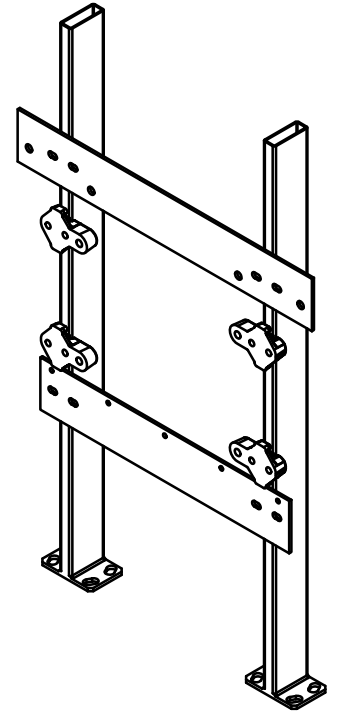

WARNING: Cancer and Reproductive Harm - www.P65Warnings.ca.gov

DATE OF LAST CHANGE: 9/01/23 JTJ

DIMENSIONS ARE SUBJECT TO MANUFACTURERS TOLERANCES AND CHANGE WITHOUT NOTICE. WE CAN ASSUME NO RESPONSIBILITY FOR USE OF SUPERSEDED OR VOID DATA.



MICHIGAN CITY, INDIANA

NOTES