

**SPECIFICATION:**

JOSAM SERIES 17550-BRAD-001 FLOOR-MOUNTED, SINGLE LAVATORY CARRIER WITH HANGER PLATE, ADJUSTABLE SUPPORTING RODS, STRUCTURAL UPRIGHTS AND WELDED FEET. DESIGNED TO SUPPORT BRADLEY LVAD1, LVQD1, LVSD1, GLX-1, AND TLX-1 LAVATORIES.

**LAVATORY CARRIER**

**FLOOR-MOUNT  
HANGER PLATE**

**SERIES 17550-BRAD-001**

RECOMMEND FEET BE SECURED TO FLOOR WITH 1/2" BOLTS AND ANCHORS BY OTHERS  
NOT ALL HARDWARE SHOWN

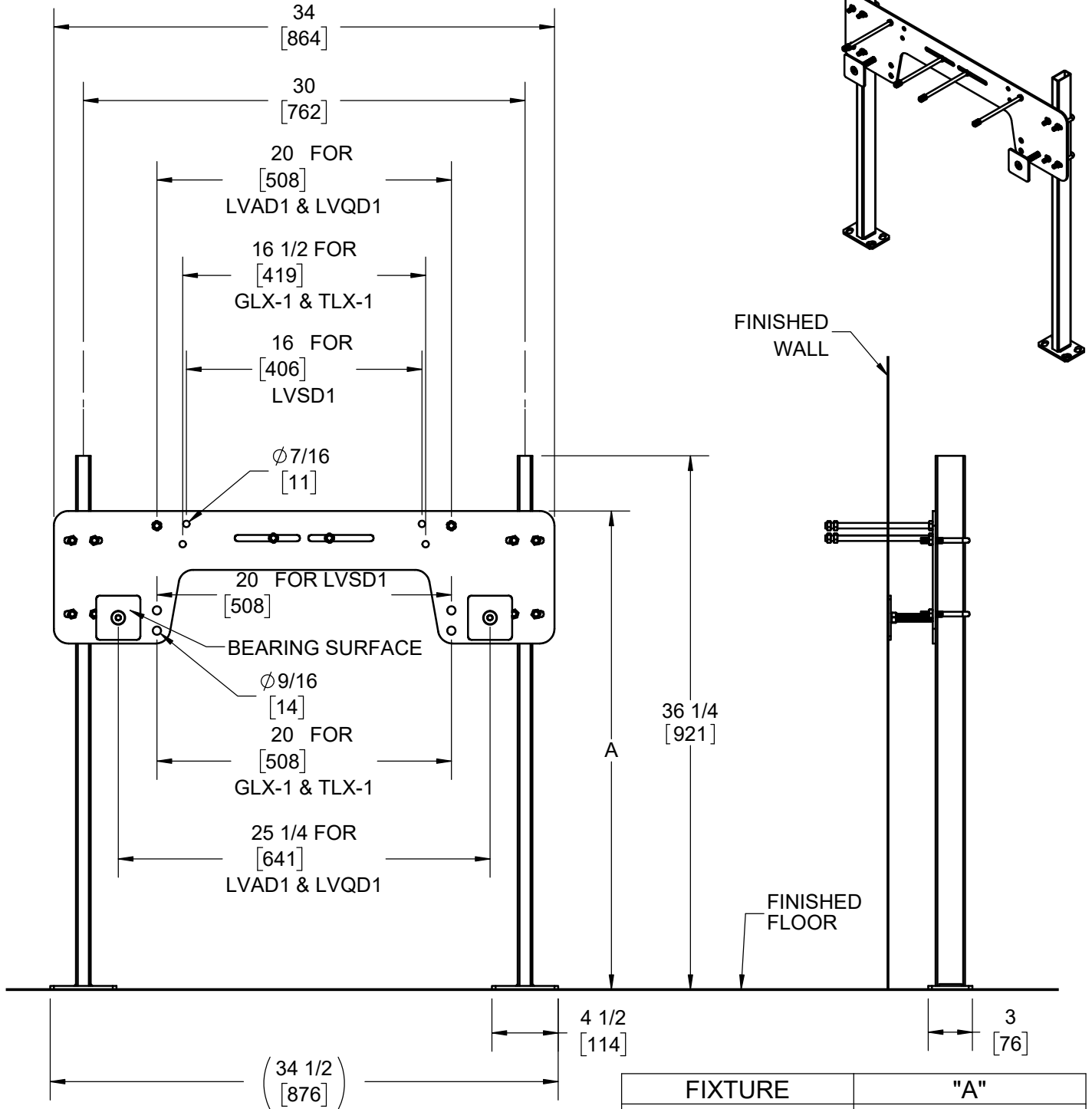

WARNING: Cancer and Reproductive Harm - www.P65Warnings.ca.gov

DATE OF LAST CHANGE: 6/07/24 JTJ

DIMENSIONS ARE SUBJECT TO MANUFACTURERS TOLERANCES AND CHANGE WITHOUT NOTICE. WE CAN ASSUME NO RESPONSIBILITY FOR USE OF SUPERSEDED OR VOID DATA.

**JOSAM**  
MICHIGAN CITY, INDIANA

NOTES